

Released Form

**North Carolina
READY End-of-Grade
Assessment
Mathematics**

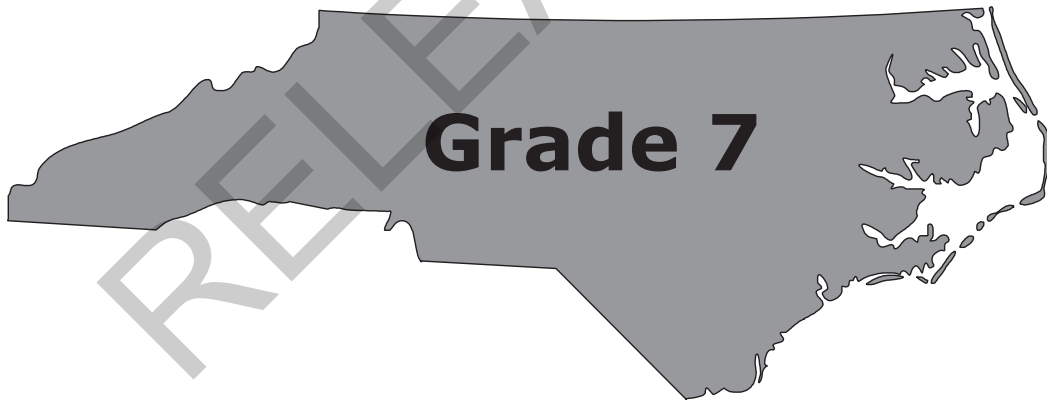

Student Booklet



Academic Services and Instructional Support
Division of Accountability Services



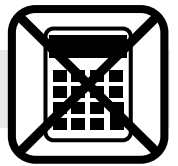

Sample Questions

S1 Kerry walks 3 miles each day. How far will she walk in 7 days?

- A 10 miles
- B 14 miles
- C 21 miles
- D 24 miles

S2 What number is represented by point P on the number line below?

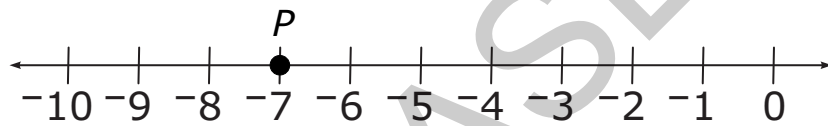

S3 What fraction of the circle is shaded?

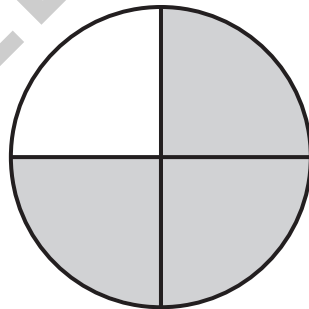

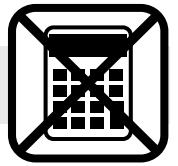

- 1 The table shows how much a store charges for certain numbers of pencils.

Number of pencils (p)	Cost (c)
4	\$0.72
7	\$1.26
12	\$2.16

Based on the table, which equation could be used to calculate the cost, c , of any number of pencils, p ?

- A $c = 0.09p$
- B $c = 0.18p$
- C $c = 0.54p$
- D $c = 0.72p$
- 2 Suppose that a butterfly can fly 82 feet in 4 seconds. A dragonfly can fly 50 feet in 2 seconds. Which can fly faster and by how much?
- A The dragonfly is 4.5 feet per second faster.
- B The dragonfly is 20.5 feet per second faster.
- C The butterfly is 4.5 feet per second faster.
- D The butterfly is 24 feet per second faster.

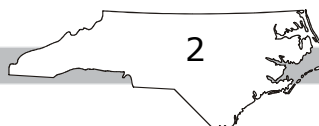

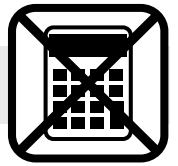

3 Chad built a scale model of a statue. He built the model 7 inches tall to represent the actual height of 15 feet. Which equation below represents the relationship between the actual height (a), in feet, and the height of the model (m), in inches?

A $a = \frac{7}{15}m$

B $m = \frac{7}{15}a$

C $a = 0.75m$

D $m = 0.75a$

4 Michelle bought the same fabric on 3 different occasions and recorded the data below.

Yards of Fabric	Total Cost
2.2	\$2.53
3.6	\$4.14
4.2	\$4.83

What was the price per yard of fabric?

A \$1.05

B \$1.10

C \$1.15

D \$1.50



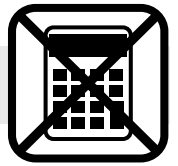

5 Mike earned the amounts listed in the table below.

Hours Worked (h)	Amount Earned (E)
15	\$183.75
22	\$269.50
26	\$318.50

Which equation could be used to find the amount of money Mike earns, E , for any number of hours worked, h ?

- A $E = 18.75 + h$
- B $E = 12.25 + h$
- C $E = 18.75h$
- D $E = 12.25h$

6 A baker made two cakes of the same size.

- At the end of the day, there was $\frac{2}{3}$ of a chocolate cake left.
- There was $\frac{5}{6}$ of a strawberry cake left.
- The baker divided the remaining chocolate cake into 2 equal pieces and the remaining strawberry cake into 3 equal pieces.

Which cake flavor had larger pieces and by how much?

- A chocolate by $\frac{1}{6}$ of a cake
- B strawberry by $\frac{1}{6}$ of a cake
- C chocolate by $\frac{1}{18}$ of a cake
- D strawberry by $\frac{1}{18}$ of a cake



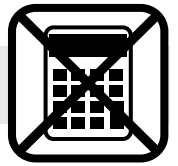

Questions 7 through 15 require you to write your answers in the boxes provided on your answer sheet. Write only one number or symbol in each box and fill in the circle in each column that matches what you have printed. Fill in only one circle in each column.

7 Betty makes pies. To make 6 pies, she uses $7\frac{1}{2}$ cups of flour. How many cups of flour are needed to make 1 pie?

8 John mixed $\frac{3}{4}$ liter of yellow paint with $1\frac{1}{4}$ liters of red paint to make 2 liters of orange paint.

- He needed more orange paint.
- To make a new batch of orange paint, he used exactly 1 liter of red paint.

Using the same ratio, how many liters of yellow paint should John use to make the new batch of orange paint?

9 One lap around a track is equal to one-eighth of a mile. A horse ran a distance of 9 laps in 2 minutes and 30 seconds. What was the horse's average speed in miles per minute?

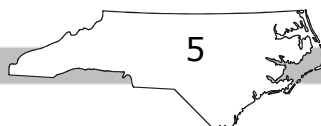

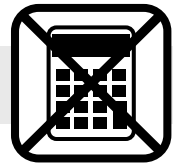

- 10 A store sells ladders.
- The retail price was a 40 percent markup over the manufacturer price.
 - A month later, the store reduced the retail price of the ladder by 25 percent.

What percent markup is the new retail price over the manufacturer price?

- 11 Mr. Adams had 24 guests at his house for a party. Each guest brought one item.
- One-third of the guests brought drinks.
 - One-fourth of the guests brought a dessert.
 - The rest of the guests brought chips.

How many guests brought chips?

- 12 A kitchen is shaped like a rectangle with dimensions of $11\frac{1}{2}$ ft by $9\frac{1}{2}$ ft. The floor of the room is made of square tiles with a side length of $\frac{1}{2}$ ft. What is the number of tiles that will cover the kitchen floor?

- 13 What is the value of $-2\left(4^2 + \left(\frac{1}{2}\right)^2\right)$?



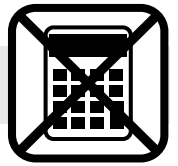

- 14 Brett made a scale drawing of a rectangular room in his house. The actual length of the room is $12\frac{4}{5}$ ft. The scale used to make the drawing was $\frac{1}{4}$ in. = 1 ft. What is the length, in inches, of the room on the drawing?

- 15 \overline{SU} intersects \overline{TV} at point R . What is the value of x , in degrees?

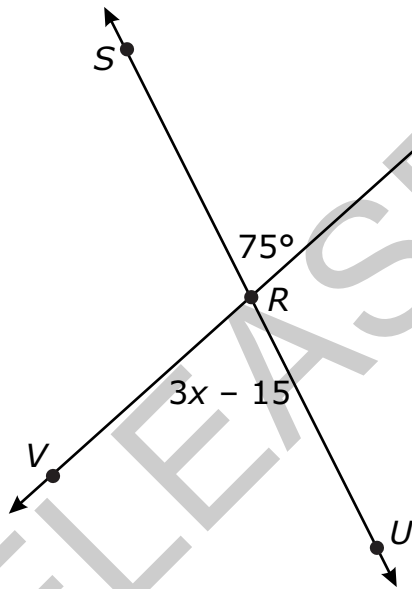

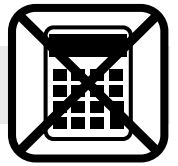

This is the end of the calculator inactive test questions.

Directions:

- 1. Look back over your answers for the calculator inactive questions. You will not be able to go back and work on these questions once you are given a calculator.**
- 2. Raise your hand to let your teacher know you are ready to begin the calculator active test questions.**
- 3. Do not begin work on the calculator active test questions until your teacher has given you a calculator.**

RELEASED

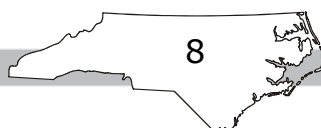

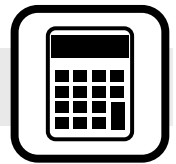

16 A notebook costs \$4.50 plus sales tax. After sales tax, the notebook is \$4.86. What is the sales tax rate?

- A 6%
- B 7%
- C 8%
- D 9%

17 The Smith family went out to dinner.

- The price of the meal was \$29.85.
- The sales tax was 6% of the price of the meal.
- The tip was 15% of the meal and the sales tax.

How much money did the Smith family pay for the meal, including tax and tip?

- A \$50.85
- B \$36.39
- C \$36.12
- D \$31.95

18 Mr. Sanchez bought 2 magazines for \$9.95 each and 1 book for \$14.95. If the sales tax is 6%, what is the total cost of Mr. Sanchez's purchases?

- A \$25.50
- B \$26.39
- C \$35.45
- D \$36.94





- 19 Which expression is equivalent to $-4(x + 2) - \frac{1}{2}(2x - 6)$?
- A $-5x - 4$
- B $-5x - 5$
- C $-8x - 4$
- D $-8x - 5$
- 20 Anna saved \$20 in a jar each month for $2\frac{1}{2}$ years. She spent 75% of her savings on a computer. How much money did Anna have left in the jar?
- A \$150
- B \$240
- C \$450
- D \$600
- 21 Mr. Jones spent \$156 to attend a college football game.
- Twenty percent of this cost was for a parking pass.
 - He spent the remainder of the money on two tickets for the game.

What was the price per ticket?

- A \$15.60
- B \$31.20
- C \$62.40
- D \$124.80

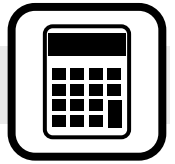

- 22 When Derek planted a tree it was 36 inches tall. The tree grew $1\frac{1}{4}$ inches per year. The tree is now $44\frac{3}{4}$ inches tall. How many years ago did Derek plant the tree?
- A 7
B 8
C 9
D 10
- 23 What is the solution to the inequality $-3x - 42 > 3$?
- A $x > -13$
B $x < -13$
C $x > -15$
D $x < -15$

RELEASED



- 24 Evan has a summer job to pick berries on a farm.
- He earns \$2.00 every 15 minutes that he picks strawberries.
 - He earns \$2.40 for every 15 minutes that he picks blueberries.
 - He picked strawberries for an hour and blueberries for 45 minutes.
- How much money did Evan earn?
- A \$4.40
B \$8.80
C \$15.20
D \$26.40
- 25 Which choice shows three lengths that **cannot** be the lengths of the three sides of a triangle?
- A 2 cm, 8 cm, 8 cm
B 2 cm, 3 cm, 6 cm
C 4 cm, 5 cm, 7 cm
D 5 cm, 6 cm, 9 cm
- 26 The circumference of a circle is 188 meters. What is the **approximate** radius of the circle?
- A 30 meters
B 60 meters
C 94 meters
D 128 meters

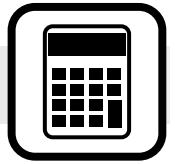

- 27 Angles T and V are complementary. Angle T has a measure of $(2x + 10)^\circ$. Angle V has a measure of 48° . What is the value of x ?
- A 16°
B 19°
C 26°
D 42°
- 28 Joe's bathroom floor is 5 feet wide and 8 feet long. He will cover the floor with 3-inch square tiles. How many tiles does Joe need?
- A 120
B 160
C 360
D 640

RELEASED

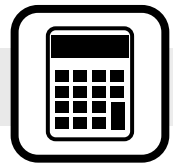

- 29 Laura’s yard is in the shape of a square and a half-circle.

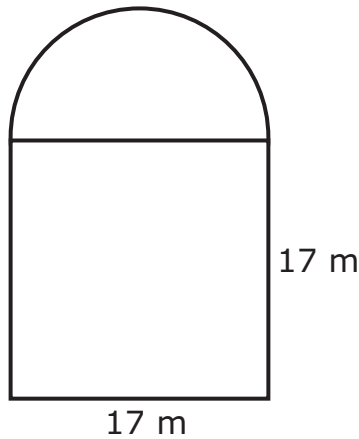

What is the **approximate** area of Laura’s yard?

- A 316 m²
 - B 402 m²
 - C 516 m²
 - D 743 m²
- 30 Hillary and Devin will collect data to find out where the seventh-grade students should take their field trip. Which group should Hillary and Devin survey to collect the **best** data?
- A the first 25 students through the lunch line
 - B ten random people from each seventh-grade class
 - C all the students in a dance class
 - D twenty of their friends



31 The chart below shows the number of miles Sam drove each day for two weeks.

	Sunday	Monday	Tuesday	Wednesday	Thursday	Friday	Saturday
Week 1	30	26	48	34	42	25	48
Week 2	32	23	50	32	44	23	218

What is the **approximate** difference in average daily miles between the two weeks?

- A 96
- B 48
- C 34
- D 24

32 Jeremy will roll a number cube, numbered 1–6, twice. What is the probability of rolling an even number, then the number 3?

- A $\frac{1}{12}$
- B $\frac{1}{6}$
- C $\frac{1}{4}$
- D $\frac{2}{3}$

RELEASED



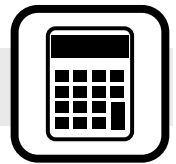

33 Veronica and James are both on a bowling team. Below are their bowling scores.

Game	Veronica	James
1	141	118
2	159	152
3	128	129
4	148	127
5	136	133

How much higher is Veronica’s median score than James’s median score?

- A 12
- B 10
- C 7
- D 3

34 Mr. Tucker earns \$250 per week working in an appliance store. In addition, he earns 2% commission on all of his sales. Last week, he sold \$2,800 worth of appliances. What was Mr. Tucker’s total income for the week?

- A \$56
- B \$287
- C \$306
- D \$467

RELEASED

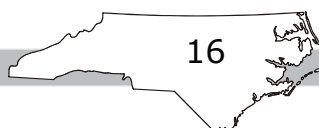

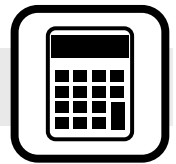

- 35 Two sporting goods stores are having discount sales on basketballs.
- At one store, a basketball is on sale for 20% off the regular price of \$24.95.
 - At the other store, the same kind of basketball is on sale for 25% off the regular price of \$25.80.

What is the difference between the sale prices of the two stores?

- A \$0.61
- B \$0.85
- C \$1.46
- D \$2.89
- 36 Which choice is equivalent to the expression shown below?

$$-3(3y - 2x) + 2(5x - 4y)$$

- A $-3y + 2x$
- B $-11y + 6x$
- C $-13y + 8x$
- D $-17y + 16x$

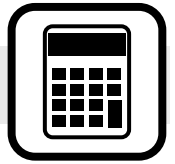

- 37 Karen spends \$450 on monthly bills. Of this total amount, 12% is for phone service, $\frac{1}{10}$ is for Internet service, and $\frac{2}{9}$ is for utilities. If the rest of the total amount is for food, how much does Karen have for food?
- A \$144.00
B \$199.00
C \$251.00
D \$277.00
- 38 Jacob is 12 years younger than twice Elizabeth's age. Jacob is 28 years old. How old is Elizabeth?
- A 8
B 14
C 16
D 20

RELEASED

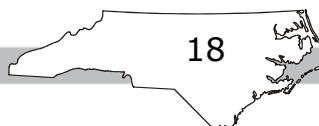



39 Which choice is a graph of the solution set for $12 - x < 8$?

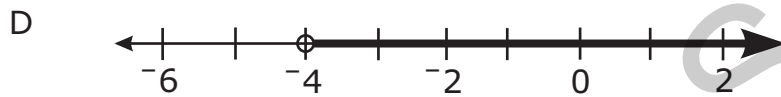
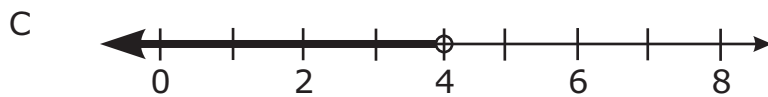
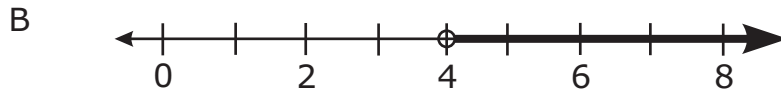
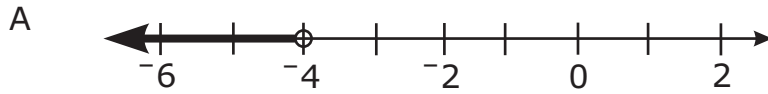

40 Which expression is equivalent to $2(x - 3) + 4x + 3$?

- A $6x$
- B $6x - 3$
- C $3x$
- D $-2x + 3$

41 What is the value of x in the equation $-2 = 5x + 3$?

- A 1
- B $\frac{1}{5}$
- C -1
- D $-3\frac{2}{5}$

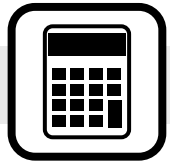

42 Which set of numbers is included in the solution set of $4 - 3x < -2$?

- A {2.5, 8, 15}
- B {-8, 0, 1.5}
- C {-15, -8, 0}
- D {0, 2.5, 8}

43 Laurie will draw a scale model of the garden she wants to plant. Her scale will be 1 cm = 2.5 ft.

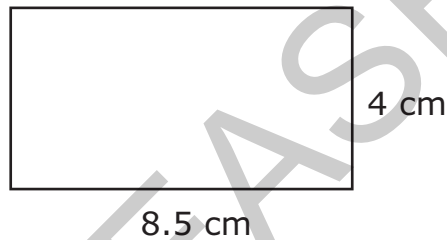

What will be the actual dimensions of Laurie's garden?

- A 1.6 ft by 3.4 ft
- B 4 ft by 34 ft
- C 8 ft by 34 ft
- D 10 ft by 21.25 ft

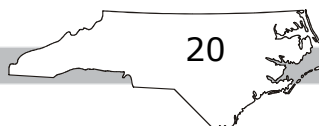

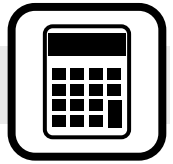

- 44 A triangular right prism is cut perpendicular to the base. What is the shape of the cross section?
- A hexagon
 - B rectangle
 - C trapezoid
 - D triangle
- 45 What is the **approximate** circumference of the circle that has a center at $(2, 1)$ and passes through the point $(2, 5)$?
- A 8 units
 - B 13 units
 - C 25 units
 - D 50 units

RELEASED



46 What is the surface area of the figure below?

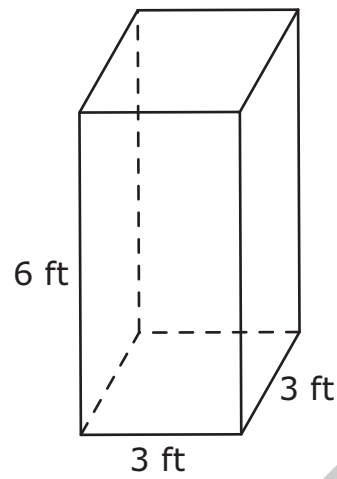

- A 12 ft^2
- B 36 ft^2
- C 54 ft^2
- D 90 ft^2

RELEASED

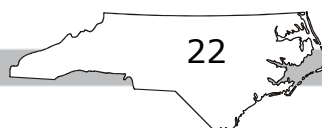

Go to the next page.



47 What is the volume of this triangular right prism?

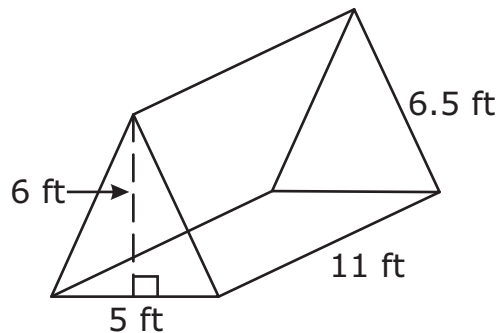

- A 165 ft^3
- B 330 ft^3
- C $1,073 \text{ ft}^3$
- D $2,145 \text{ ft}^3$

48 The table below shows the grades for three students on five assignments.

Student	Grades
1	77, 80, 100, 75, 82
2	84, 92, 80, 82, 85
3	88, 80, 79, 85, 90

Which statement below is true about the mean absolute deviation (MAD) of the students?

- A MAD of Student 3 = MAD of Student 1
- B MAD of Student 2 = MAD of Student 1
- C MAD of Student 1 < MAD of Student 3
- D MAD of Student 1 > MAD of Student 2

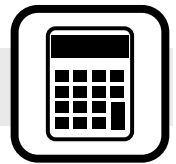

49 Terry placed 6 number tiles labeled 4, 7, 10, 11, 14, and 21 in a box. He will pick one of the number tiles from the box without looking. What is the probability Terry will pick a tile labeled with an even number?

A $\frac{2}{3}$

B $\frac{1}{2}$

C $\frac{1}{3}$

D $\frac{1}{6}$

50 The table below shows the different choices for making a shake at a restaurant. Joey will randomly select one dairy, one fruit, and one topping choice.

Dairy Choices	Fruit Choices	Topping Choices
ice cream	pineapple	peanuts
yogurt	strawberry	granola
	banana	

What is the probability that Joey’s shake will be made with ice cream, pineapple, and granola?

A $\frac{1}{12}$

B $\frac{1}{6}$

C $\frac{3}{12}$

D $\frac{3}{7}$

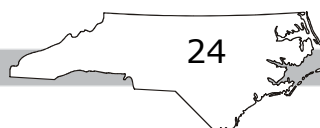

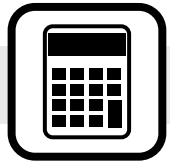

Directions:

This is the end of the mathematics test.

- 1. Put all of your papers inside your test book and close your test book.**
- 2. Place your calculator on top of the test book.**
- 3. Stay quietly in your seat until your teacher tells you that testing is finished.**

RELEASED

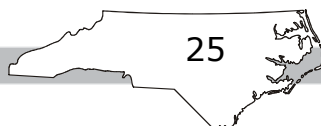

GRADE 7 MATH—RELEASED FORM

Grade 7 Math RELEASED Form 2012–2013 Answer Key

Item Number	Type	Key	Domain
S1	MC	C	
S2	GR	-7	
S3	GR	$\frac{3}{4}$ or .75	

Calculator Inactive



Item Number	Type	Key	Domain
1	MC	B	RP — Ratio and Proportional Relationships
2	MC	A	RP — Ratio and Proportional Relationships
3	MC	B	RP — Ratio and Proportional Relationships
4	MC	C	RP — Ratio and Proportional Relationships
5	MC	D	RP — Ratio and Proportional Relationships
6	MC	C	NS — The Number System
7	GR	1.25	RP — Ratio and Proportional Relationships
8	GR	.6	RP — Ratio and Proportional Relationships
9	GR	.45	RP — Ratio and Proportional Relationships
10	GR	5	NS — The Number System
11	GR	10	NS — The Number System
12	GR	437	NS — The Number System
13	GR	-32.5	NS — The Number System
14	GR	3.2	G — Geometry
15	GR	30	G — Geometry

GRADE 7 MATH—RELEASED FORM

Calculator Active



Item Number	Type	Key	Domain
16	MC	C	RP — Ratio and Proportional Relationships
17	MC	B	RP — Ratio and Proportional Relationships
18	MC	D	RP — Ratio and Proportional Relationships
19	MC	B	EE — Expressions and Equations
20	MC	A	EE — Expressions and Equations
21	MC	C	EE — Expressions and Equations
22	MC	A	EE — Expressions and Equations
23	MC	D	EE — Expressions and Equations
24	MC	C	EE — Expressions and Equations
25	MC	B	G — Geometry
26	MC	A	G — Geometry
27	MC	A	G — Geometry
28	MC	D	G — Geometry
29	MC	B	G — Geometry
30	MC	B	SP — Statistics and Probability
31	MC	D	SP — Statistics and Probability
32	MC	A	SP — Statistics and Probability
33	MC	A	SP — Statistics and Probability
34	MC	C	RP — Ratio and Proportional Relationships
35	MC	A	RP — Ratio and Proportional Relationships
36	MC	D	EE — Expressions and Equations
37	MC	C	EE — Expressions and Equations

GRADE 7 MATH—RELEASED FORM

Item Number	Type	Key	Domain
38	MC	D	EE — Expressions and Equations
39	MC	B	EE — Expressions and Equations
40	MC	B	EE — Expressions and Equations
41	MC	C	EE — Expressions and Equations
42	MC	A	EE — Expressions and Equations
43	MC	D	G — Geometry
44	MC	B	G — Geometry
45	MC	C	G — Geometry
46	MC	D	G — Geometry
47	MC	A	G — Geometry
48	MC	D	SP — Statistics and Probability
49	MC	B	SP — Statistics and Probability
50	MC	A	SP — Statistics and Probability

Item Types:

MC = multiple choice

GR = gridded response

Links to instructions for the gridded-response items can be found on the [main accountability page](#).